

8.2.2 CU-E9PKE CU-E12PKE CU-E15PKE

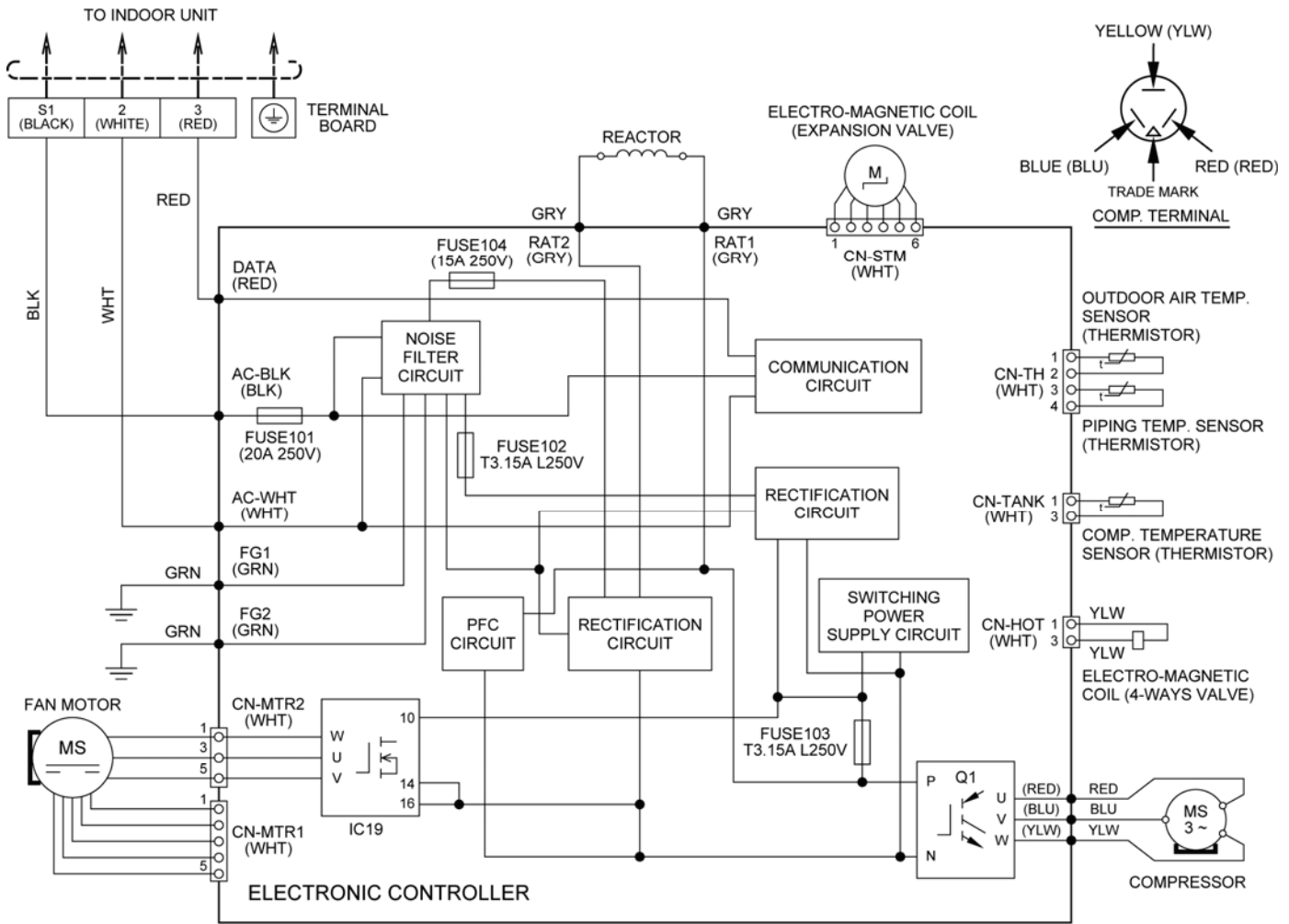

REMARKS

BLACK: (BLK) WHITE: (WHT) YELLOW: (YLW) ORANGE: (ORG)
YELLOW/GREEN: (YLW/GRN) BLUE: (BLU) RED: (R) BROWN: (BRW)

Resistance of Compressor Windings

MODEL	CU-E9PKE
CONNECTION	5RS102XBC21 (Ω)
U-V	0.858
U-W	0.858
V-W	0.858

Note: Resistance at 20°C of ambient temperature.

Resistance of Compressor Windings

MODEL	CU-E12PKE / CU-E15PKE
CONNECTION	5RS102XNA21 (Ω)
U-V	1.211
U-W	1.211
V-W	1.211

Note: Resistance at 20°C of ambient temperature.